Low power quad operational amplifier

Features

- Wide gain bandwidth: 1.3MHz
- Input common-mode voltage range includes negative rail
- Large voltage gain: 100dB
- Very low supply current per amp: 375 μ A
- Low input bias current: 20nA
- Low input offset current: 2nA
- Wide power supply range:
 - Single supply: +3V to +30V
 - Dual supplies: \pm 1.5V to \pm 15V

Description

This circuit consists of four independent, high gain, internally frequency compensated operational amplifiers designed especially for automotive and industrial control systems.

It operates from a single power supply over a wide range of voltages. Operation from split power supplies is also possible and the low power supply current drain is independent of the magnitude of the power supply voltage.



N
DIP14
(Plastic package)



D
SO-14
(Plastic micropackage)



P
TSSOP14
(Thin shrink small outline package)

1 Schematic diagram

Figure 1. Schematic diagram (1/4 LM2902)

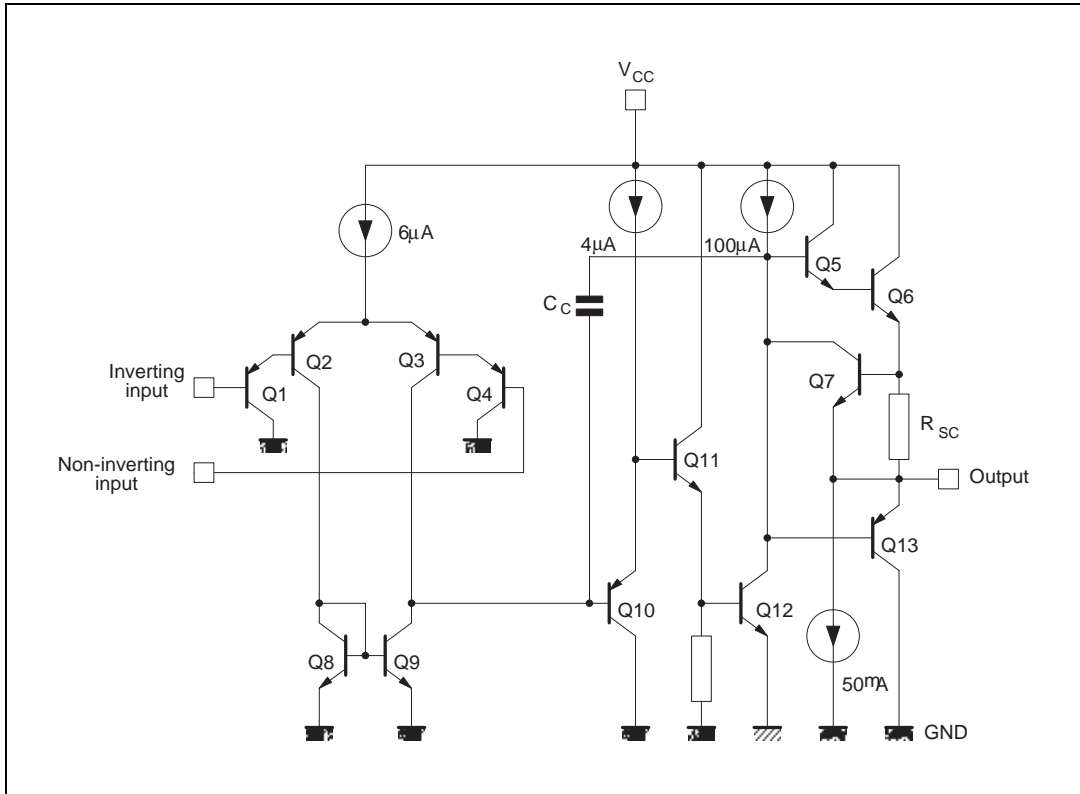
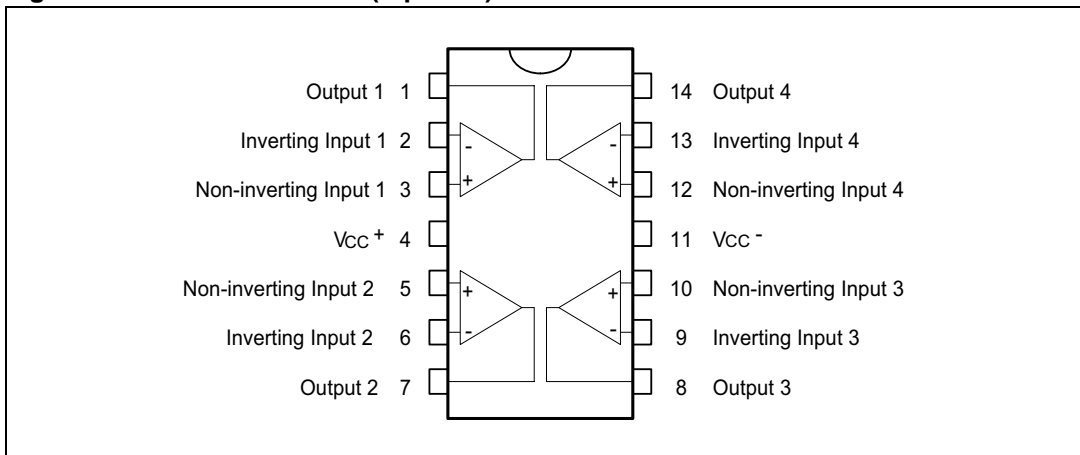

Figure 2. Pin connections (top view)



2 Absolute maximum ratings

Table 1. Absolute maximum ratings (AMR)

Symbol	Parameter	Value	Unit
V_{CC}	Supply voltage ⁽¹⁾	±16 to 33	V
V_{id}	Differential input voltage ⁽²⁾	+32	V
V_{in}	Input voltage	-0.3 to +32	V
	Output short-circuit duration ⁽³⁾	Infinite	s
T_j	Maximum junction temperature	150	°C
I_{in}	Input current ⁽⁴⁾	50	mA
T_{stg}	Storage temperature range	-65 to +150	°C
R_{thja}	Thermal resistance junction to ambient ⁽⁵⁾		
	SO-14	105	°C/W
	TSSOP14	100	
DIP14	80		
R_{thjc}	Thermal resistance junction to case ⁽⁵⁾		
	SO-14	31	°C/W
	TSSOP14	32	
DIP14	33		
ESD	HBM: human body model ⁽⁶⁾	370	V
	MM: machine model ⁽⁷⁾	150	V
	CDM: charged device model ⁽⁸⁾	1500	V

- All voltage values, except differential voltage are with respect to network ground terminal.
- Differential voltages are the non-inverting input terminal with respect to the inverting input terminal.
- Short-circuit from the output to V_{CC}^+ can cause excessive heating and eventual destruction. The maximum output current is approximately 20mA, independent of the magnitude of V_{CC}^+ .
- This input current only exists when the voltage at any of the input leads is driven negative. It is due to the collector-base junction of the input PNP transistor becoming forward biased and thereby acting as input diodes clamps. In addition to this diode action, there is also NPN parasitic action on the IC chip. This transistor action can cause the output voltages of the op-amps to go to the V_{CC} voltage level (or to ground for a large overdrive) for the time duration than an input is driven negative. This is not destructive and normal output will set up again for input voltage higher than -0.3V.
- $R_{thja/c}$ are typical values.
- Human body model: A 100pF capacitor is charged to the specified voltage, then discharged through a 1.5kΩ resistor between two pins of the device. This is done for all couples of connected pin combinations while the other pins are floating.
- Machine model: A 200pF capacitor is charged to the specified voltage, then discharged directly between two pins of the device with no external series resistor (internal resistor < 5Ω). This is done for all couples of connected pin combinations while the other pins are floating.
- Charged device model: all pins and the package are charged together to the specified voltage and then discharged directly to the ground through only one pin. This is done for all pins.

3 Operating conditions

Table 2. Operating conditions

Symbol	Parameter	Value	Unit
V_{CC}	Supply voltage	3 to 30	V
V_{icm}	Common mode input voltage range $T_{min} \leq T_{amb} \leq T_{max}$	$V_{CC}^+ - 1.5$ $V_{CC}^+ - 2$	V
T_{oper}	Operating free-air temperature range	-40 to +125	°C

4 Electrical characteristics

Table 3. $V_{CC}^+ = 5V$, $V_{CC}^- = \text{Ground}$, $V_o = 1.4V$, $T_{amb} = 25^\circ C$ (unless otherwise specified)

Symbol	Parameter	Min.	Typ.	Max.	Unit
V_{io}	Input offset voltage ⁽¹⁾ $T_{min} \leq T_{amb} \leq T_{max}$		2	7 9	mV
DV_{io}	Input offset voltage drift		7	30	$\mu V/^\circ C$
I_{io}	Input offset current $T_{min} \leq T_{amb} \leq T_{max}$		2	30 40	nA
DI_{io}	Input offset current drift		10	200	$pA/^\circ C$
I_{ib}	Input bias current ⁽²⁾ $T_{min} \leq T_{amb} \leq T_{max}$		20	150 300	nA
A_{vd}	Large signal voltage gain $V_{CC}^+ = +15V$, $R_L = 2k\Omega$, $V_o = 1.4V$ to $11.4V$ $T_{min} \leq T_{amb} \leq T_{max}$	50 25	100		V/mV
SVR	Supply voltage rejection ratio ($R_S \leq 10k\Omega$) $T_{min} \leq T_{amb} \leq T_{max}$	65 65	110		dB
I_{cc}	Supply current, all amps, no load $V_{CC}^+ = +5V$ $V_{CC}^+ = +30V$ $T_{min} \leq T_{amb} \leq T_{max}$ $V_{CC}^+ = +5V$ $V_{CC}^+ = +30V$		0.7 1.5	1.2 3	mA
CMR	Common-mode rejection ratio ($R_S \leq 10k\Omega$) $T_{min} \leq T_{amb} \leq T_{max}$	70 60	80		dB
I_o	Output short-circuit current ($V_{id} = +1V$) $V_{CC}^+ = +15V$, $V_o = +2V$	20	40	70	mA
I_{sink}	Output sink current ($V_{id} = -1V$) $V_{CC}^+ = +15V$, $V_o = +2V$ $V_{CC}^+ = +15V$, $V_o = +0.2V$	10 12	20 50		mA μA
V_{OH}	High level output voltage $V_{CC}^+ = +30V$ $R_L = 2k\Omega$ $T_{min} \leq T_{amb} \leq T_{max}$ $R_L = 10k\Omega$ $T_{min} \leq T_{amb} \leq T_{max}$ $V_{CC}^+ = +5V$, $R_L = 2k\Omega$ $T_{min} \leq T_{amb} \leq T_{max}$	26 26 27 27 3 3.5	27 28		V
V_{OL}	Low level output voltage ($R_L = 10k\Omega$) $T_{min} \leq T_{amb} \leq T_{max}$		5	20 20	mV
SR	Slew rate $V_{CC}^+ = 15V$, $V_{in} = 0.5$ to $3V$, $R_L = 2k\Omega$, $C_L = 100pF$, unity gain		0.4		V/ μs

Table 3. $V_{CC}^+ = 5V$, $V_{CC}^- = \text{Ground}$, $V_o = 1.4V$, $T_{amb} = 25^\circ C$ (unless otherwise specified)

Symbol	Parameter	Min.	Typ.	Max.	Unit
GBP	Gain bandwidth product $V_{CC}^+ = 30V$, $V_{in} = 10mV$, $R_L = 2k\Omega$, $C_L = 100pF$		1.3		MHz
THD	Total harmonic distortion $f = 1kHz$, $A_V = 20dB$, $R_L = 2k\Omega$, $V_o = 2V_{pp}$, $C_L = 100pF$, $V_{CC}^+ = 30V$		0.015		%
e_n	Equivalent input noise voltage $f = 1kHz$, $R_S = 100\Omega$, $V_{CC}^+ = 30V$		40		$\frac{nV}{\sqrt{Hz}}$
V_{O1}/V_{O2}	Channel separation ⁽³⁾ $1kHz \leq f \leq 20kHz$		120		dB

- $V_o = 1.4V$, $R_S = 0\Omega$, $5V < V_{CC}^+ < 30V$, $0V < V_{ic} < V_{CC}^+ - 1.5V$.
- The direction of the input current is out of the IC. This current is essentially constant, independent of the state of the output, so there is no change in the loading charge on the input lines.
- Due to the proximity of external components ensure stray capacitance does not cause coupling between these external parts. This typically can be detected as this type of capacitance increases at higher frequencies.

Figure 3. Input bias current vs. T_{amb}

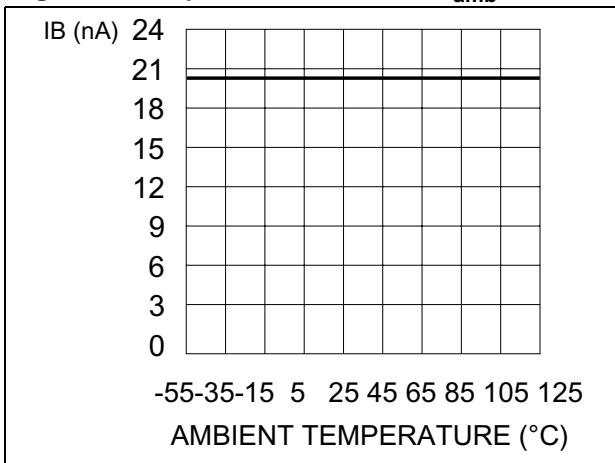

Figure 4. Input voltage range

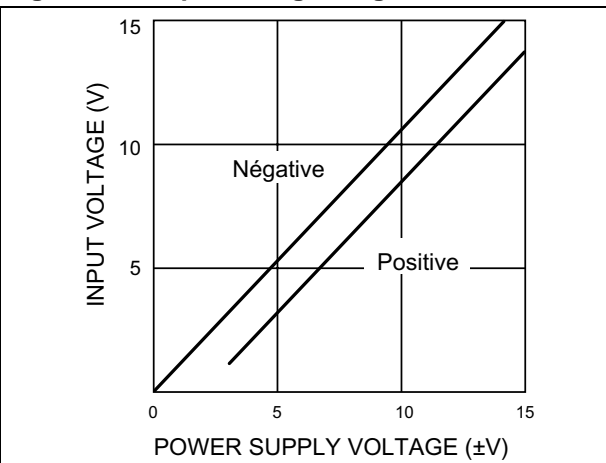

Figure 5. Current limiting

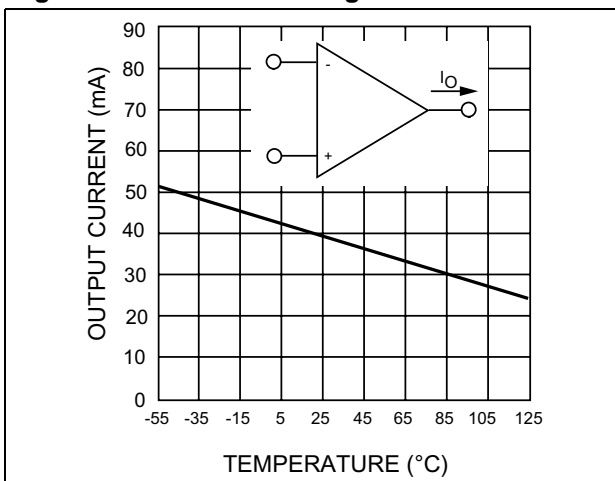

Figure 6. Supply current

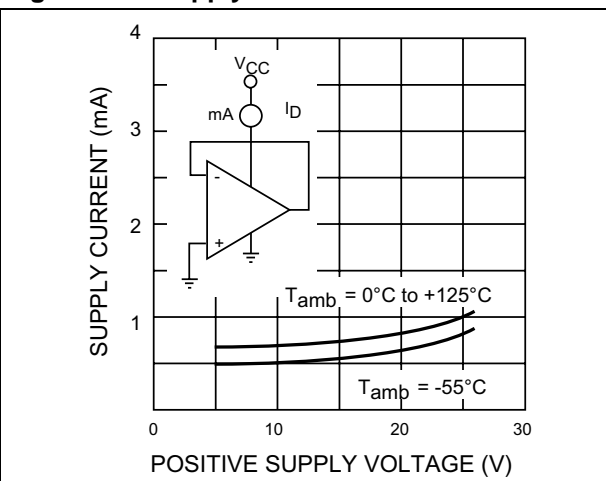

Figure 7. Gain bandwidth product

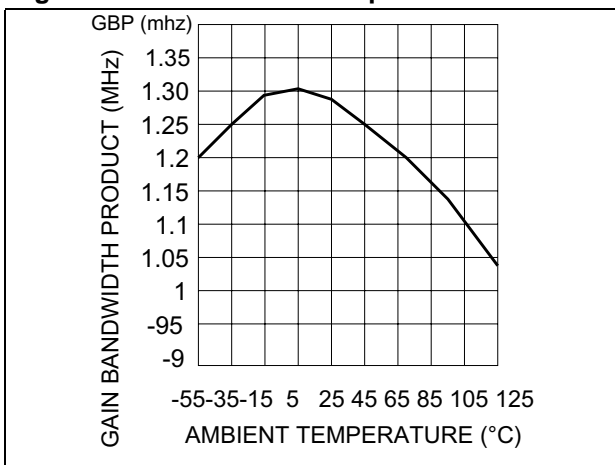

Figure 8. Voltage follower pulse response

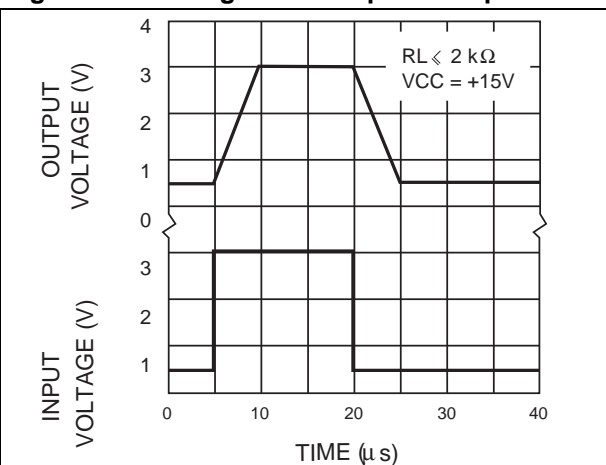

Figure 9. Common mode rejection ratio

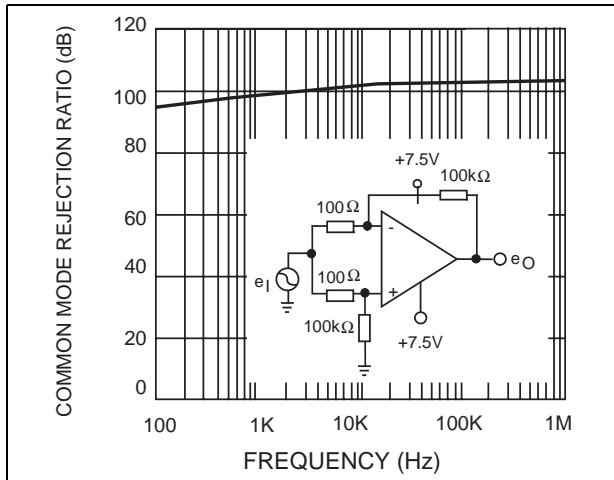

Figure 10. Output characteristics

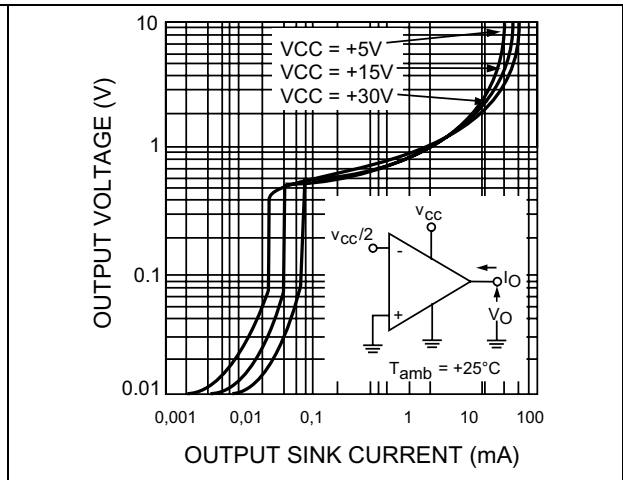

Figure 11. Open loop frequency response

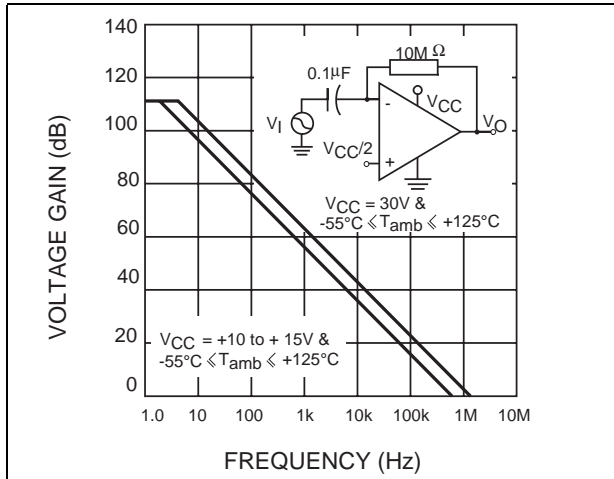

Figure 12. Voltage follower pulse response

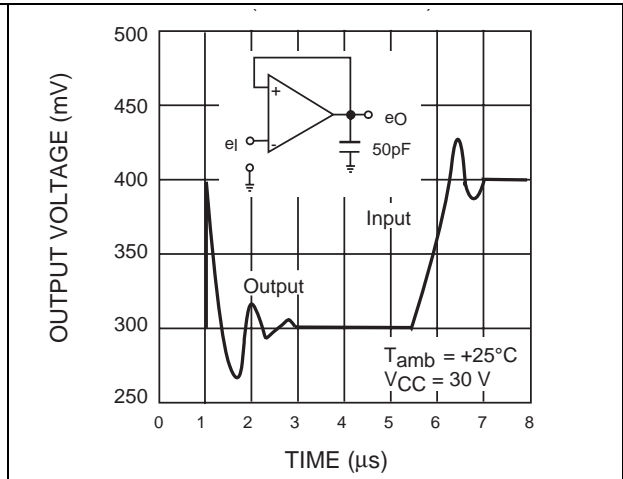

Figure 13. Large signal frequency response

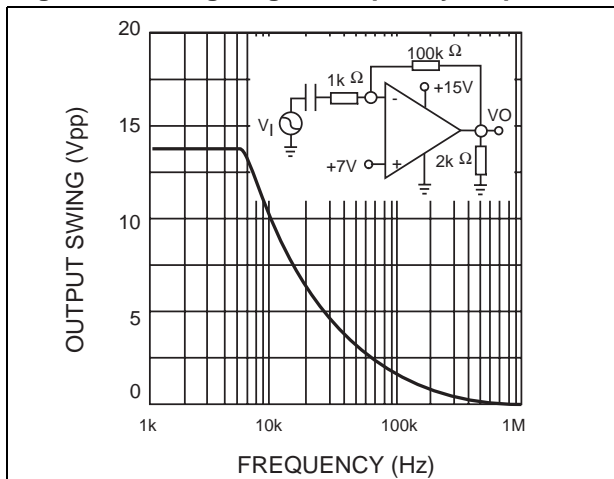

Figure 14. Output characteristics

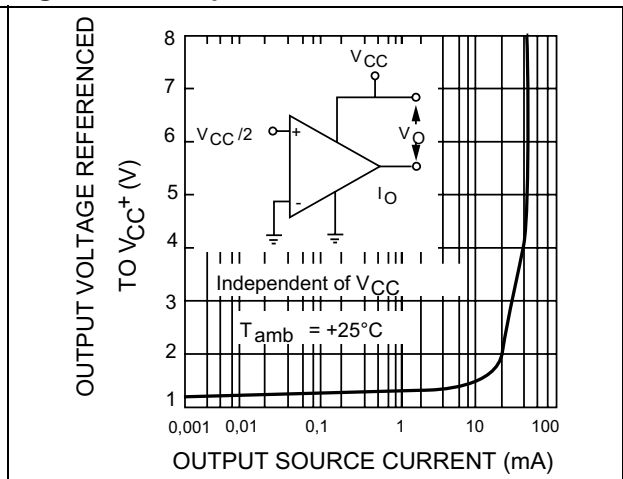

Figure 15. Input current

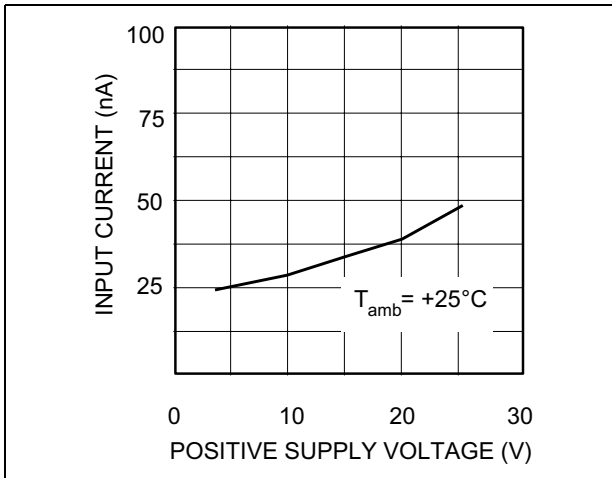

Figure 16. Voltage gain

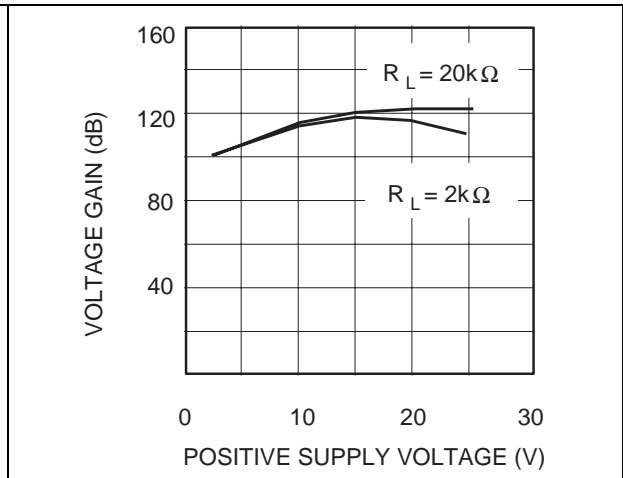

Figure 17. Power supply and common mode rejection ratio

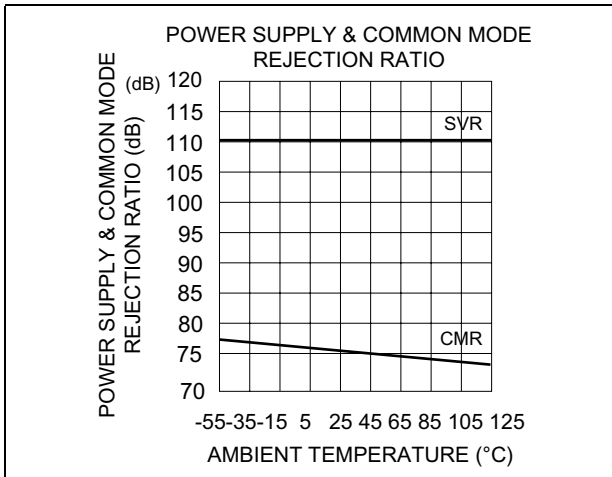
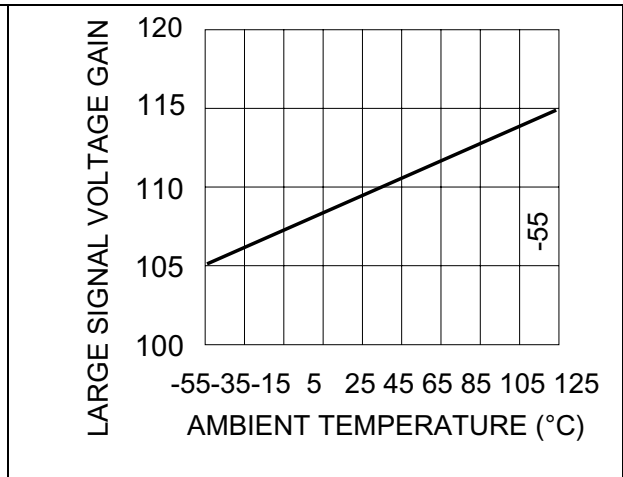

Figure 18. Large signal voltage gain



5 Typical single-supply applications

Figure 19. AC coupled inverting amplifier

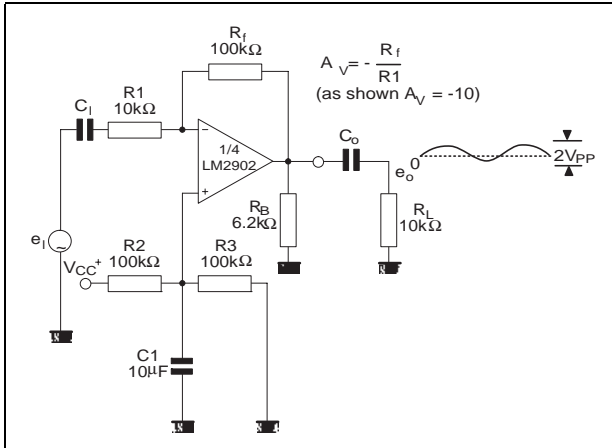

Figure 20. AC coupled non-inverting amplifier

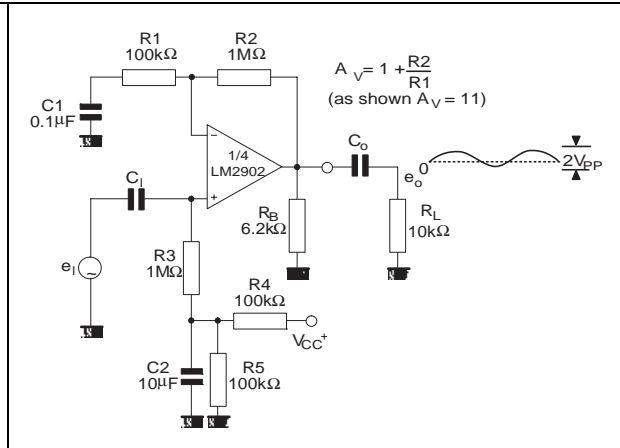

Figure 21. Non-inverting DC gain

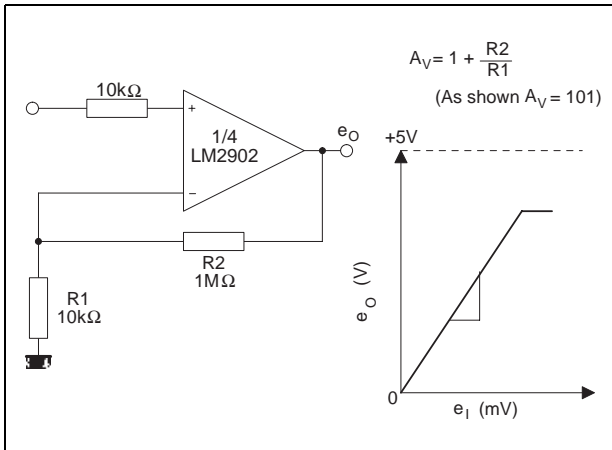

Figure 22. DC summing amplifier

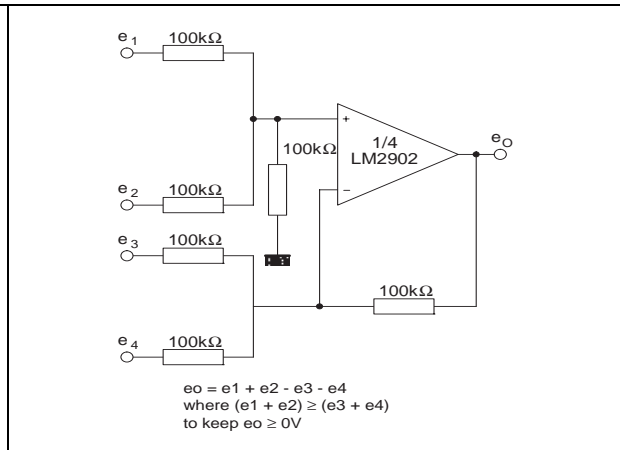

Figure 23. Active bandpass filter

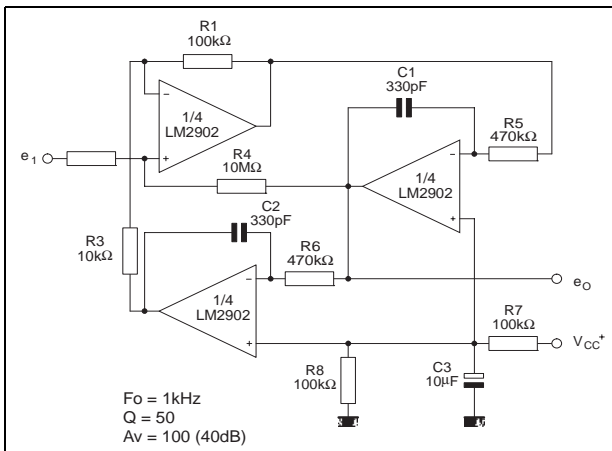

Figure 24. High input Z adjustable gain DC instrumentation amplifier

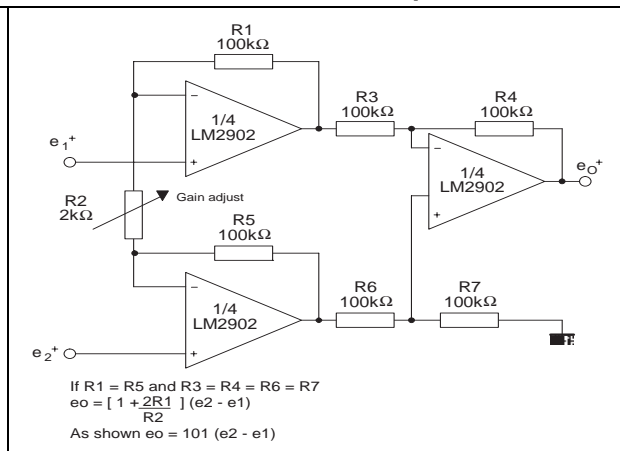

Figure 25. High input Z, DC differential amplifier

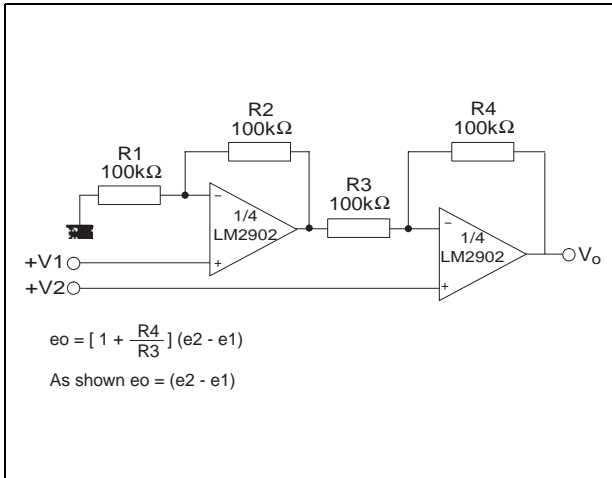

Figure 26. Low drift peak detector

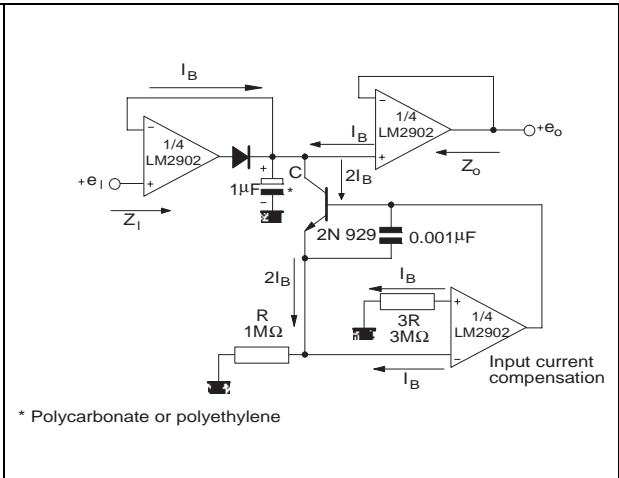
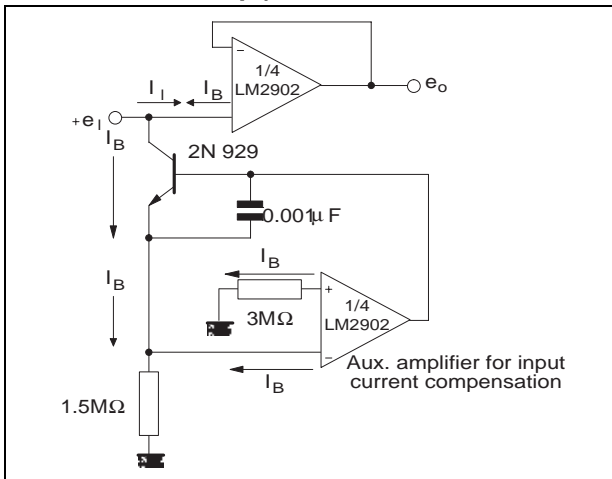

Figure 27. Using symmetrical amplifiers to reduce input current (general concept)



6 Package information

In order to meet environmental requirements, ST offers these devices in ECOPACK® packages. These packages have a lead-free second level interconnect. The category of second level interconnect is marked on the package and on the inner box label, in compliance with JEDEC Standard JESD97. The maximum ratings related to soldering conditions are also marked on the inner box label. ECOPACK is an ST trademark. ECOPACK specifications are available at: www.st.com.

6.1 DIP14 package information

Figure 28. DIP14 package mechanical drawing

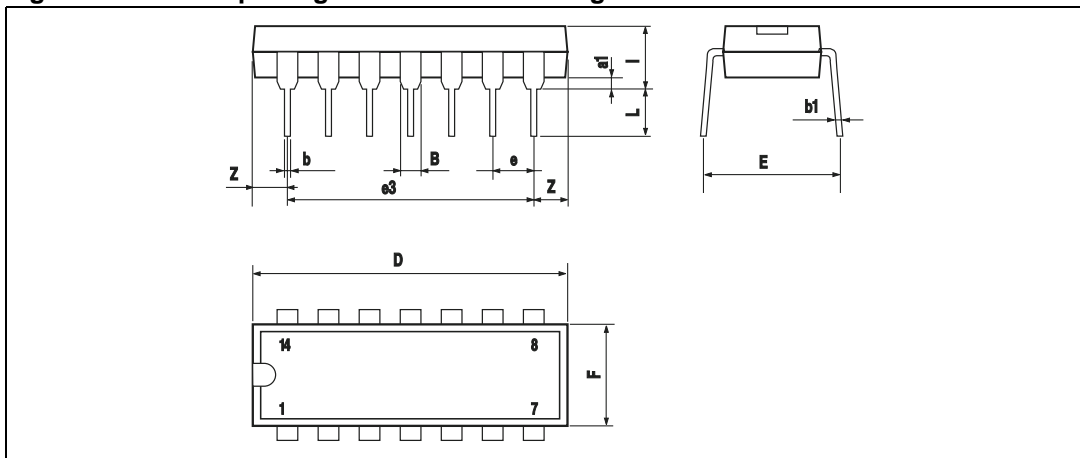

Table 4. DIP14 package mechanical data

Ref.	Millimeters			Inches		
	Min.	Typ.	Max.	Min.	Typ.	Max.
a1	0.51			0.020		
B	1.39		1.65	0.055		0.065
b		0.5			0.020	
b1		0.25			0.010	
D			20			0.787
E		8.5			0.335	
e		2.54			0.100	
e3		15.24			0.600	
F			7.1			0.280
I			5.1			0.201
L		3.3			0.130	
Z	1.27		2.54	0.050		0.100

6.2 SO-14 package information

Figure 29. SO-14 package mechanical drawing

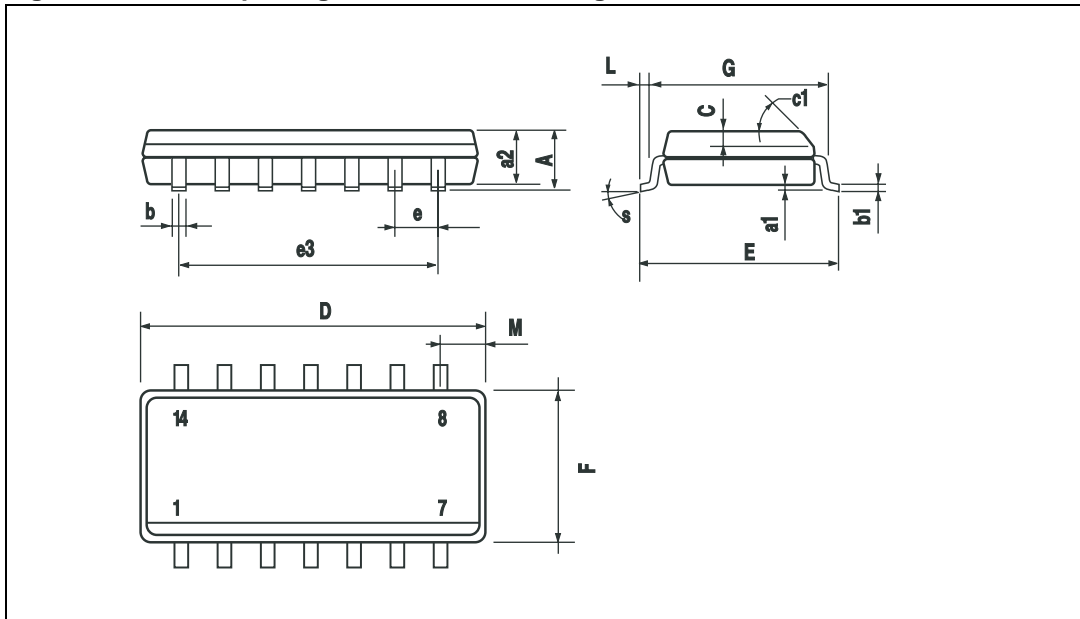

Table 5. SO-14 package mechanical data

Ref.	Dimensions					
	Millimeters			Inches		
	Min.	Typ.	Max.	Min.	Typ.	Max.
A			1.75			0.068
a1	0.1		0.2	0.003		0.007
a2			1.65			0.064
b	0.35		0.46	0.013		0.018
b1	0.19		0.25	0.007		0.010
C		0.5			0.019	
c1	45° (typ.)					
D	8.55		8.75	0.336		0.344
E	5.8		6.2	0.228		0.244
e		1.27			0.050	
e3		7.62			0.300	
F	3.8		4.0	0.149		0.157
G	4.6		5.3	0.181		0.208
L	0.5		1.27	0.019		0.050
M			0.68			0.026
S	8° (max.)					

6.3 TSSOP14 package information

Figure 30. TSSOP14 package mechanical drawing

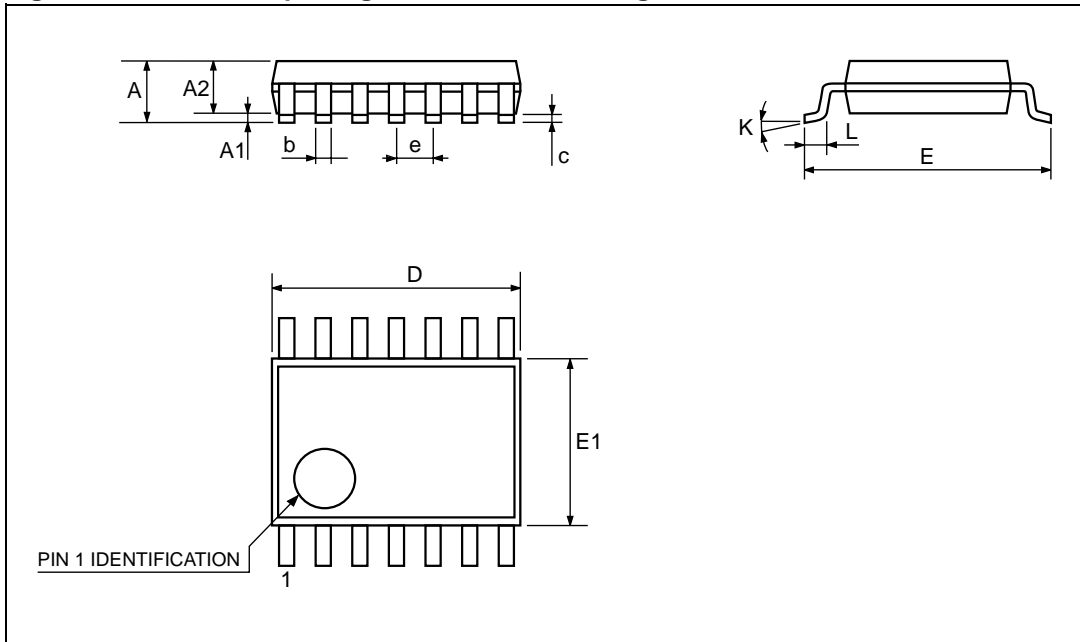

Table 6. TSSOP14 package mechanical data

Ref.	Dimensions					
	Millimeters			Inches		
	Min.	Typ.	Max.	Min.	Typ.	Max.
A			1.2			0.047
A1	0.05		0.15	0.002	0.004	0.006
A2	0.8	1	1.05	0.031	0.039	0.041
b	0.19		0.30	0.007		0.012
c	0.09		0.20	0.004		0.0089
D	4.9	5	5.1	0.193	0.197	0.201
E	6.2	6.4	6.6	0.244	0.252	0.260
E1	4.3	4.4	4.48	0.169	0.173	0.176
e		0.65 BSC			0.0256 BSC	
K	0°		8°	0°		8°
L1	0.45	0.60	0.75	0.018	0.024	0.030

7 Ordering information

Table 7. Order codes

Order code	Temperature range	Package	Packing	Marking
LM2902N	-40°C, +125°C	DIP14	Tube	LM2902N
LM2902D LM2902DT		SO-14	Tube or tape & reel	2902
LM2902PT		TSSOP14 (Thin shrink outline package)	Tape & reel	
LM2902YD ⁽¹⁾ LM2902YDT ⁽¹⁾		SO-14 (Automotive grade level)	Tube or tape & reel	2902Y
LM2902YPT ⁽²⁾		TSSOP14 (Automotive grade level)	Tape & reel	

1. Qualified and characterized according to AEC Q100 and Q003 or equivalent, advanced screening according to AEC Q001 & Q 002 or equivalent.
2. Qualification and characterization according to AEC Q100 and Q003 or equivalent, advanced screening according to AEC Q001 & Q 002 or equivalent are on-going.

8 Revision history

Date	Revision	Changes
30-Nov-2001	1	Initial release.
1-Jul-2005	2	PPAP references inserted in the datasheet, see Table 7: Order codes . ESD protection inserted in Table 1 on page 3 .
31-Oct-2005	3	An error in the device description was corrected on page 1. PPAP reference inserted in the datasheet see Table 7: Order codes . Minor grammatical and formatting changes throughout.
18-Jun-2007	4	Values for thermal resistance junction to ambient and ESD HBM corrected in Table 1: Absolute maximum ratings (AMR) . Values for thermal resistance junction to case added in Table 1: Absolute maximum ratings (AMR) . Table 2: Operating conditions added. Electrical characteristics figure captions updated. Section 6: Package information updated. Table 7: Order codes moved to end of document.
18-Dec-2007	5	Removed power dissipation parameter from AMR table and added maximum junction temperature. Updated footnotes for automotive grade order codes. Updated format of package information.

Please Read Carefully:

Information in this document is provided solely in connection with ST products. STMicroelectronics NV and its subsidiaries ("ST") reserve the right to make changes, corrections, modifications or improvements, to this document, and the products and services described herein at any time, without notice.

All ST products are sold pursuant to ST's terms and conditions of sale.

Purchasers are solely responsible for the choice, selection and use of the ST products and services described herein, and ST assumes no liability whatsoever relating to the choice, selection or use of the ST products and services described herein.

No license, express or implied, by estoppel or otherwise, to any intellectual property rights is granted under this document. If any part of this document refers to any third party products or services it shall not be deemed a license grant by ST for the use of such third party products or services, or any intellectual property contained therein or considered as a warranty covering the use in any manner whatsoever of such third party products or services or any intellectual property contained therein.

UNLESS OTHERWISE SET FORTH IN ST'S TERMS AND CONDITIONS OF SALE ST DISCLAIMS ANY EXPRESS OR IMPLIED WARRANTY WITH RESPECT TO THE USE AND/OR SALE OF ST PRODUCTS INCLUDING WITHOUT LIMITATION IMPLIED WARRANTIES OF MERCHANTABILITY, FITNESS FOR A PARTICULAR PURPOSE (AND THEIR EQUIVALENTS UNDER THE LAWS OF ANY JURISDICTION), OR INFRINGEMENT OF ANY PATENT, COPYRIGHT OR OTHER INTELLECTUAL PROPERTY RIGHT.

UNLESS EXPRESSLY APPROVED IN WRITING BY AN AUTHORIZED ST REPRESENTATIVE, ST PRODUCTS ARE NOT RECOMMENDED, AUTHORIZED OR WARRANTED FOR USE IN MILITARY, AIR CRAFT, SPACE, LIFE SAVING, OR LIFE SUSTAINING APPLICATIONS, NOR IN PRODUCTS OR SYSTEMS WHERE FAILURE OR MALFUNCTION MAY RESULT IN PERSONAL INJURY, DEATH, OR SEVERE PROPERTY OR ENVIRONMENTAL DAMAGE. ST PRODUCTS WHICH ARE NOT SPECIFIED AS "AUTOMOTIVE GRADE" MAY ONLY BE USED IN AUTOMOTIVE APPLICATIONS AT USER'S OWN RISK.

Resale of ST products with provisions different from the statements and/or technical features set forth in this document shall immediately void any warranty granted by ST for the ST product or service described herein and shall not create or extend in any manner whatsoever, any liability of ST.

ST and the ST logo are trademarks or registered trademarks of ST in various countries.

Information in this document supersedes and replaces all information previously supplied.

The ST logo is a registered trademark of STMicroelectronics. All other names are the property of their respective owners.

© 2007 STMicroelectronics - All rights reserved

STMicroelectronics group of companies

Australia - Belgium - Brazil - Canada - China - Czech Republic - Finland - France - Germany - Hong Kong - India - Israel - Italy - Japan - Malaysia - Malta - Morocco - Singapore - Spain - Sweden - Switzerland - United Kingdom - United States of America

www.st.com